

Electrical Adjustments

I. PLEASE READ BEFORE ATTEMPTING SERVICE

1. Never disconnect any leads while receiver is in operation.
2. Disconnect all power before attempting any repairs.
3. Do not short any portion of the circuit while power is on.
4. For safety reasons, all parts replaced should be identical, (for parts and part numbers see parts list).
5. Before alignment the set must be pre-heated for 30 minutes or more and erase magnetism thoroughly from CRT front chassis frame by erase coil.

II. TEST EQUIPMENT

1. VIF Sweep Generator
2. SIF Sweep Generator
3. DC Power Supply (14V)
4. Oscilloscope
5. Digital Multi Meter
6. CRT Colour Analyzer
7. Demagnetizing Coil
8. Philips Pattern Generator
9. Frequency Counter

III. TANK COIL ALIGNMENT

- #### A. PREPARATION STEP (SEE FIG.2)
1. Connect OUTPUT lead of VIF Sweep Generator between SA101 Pin 4 and ground.
 2. Connect lead of FROM DET between TP106 (Pin 19 of IC101) and ground.
 3. Apply a +14V DC to lead of D408.
 4. Apply a AGC bias (approx 6.14V) to TP104. Slowly adjust the AGC bias voltage until the waveform is just before saturation.

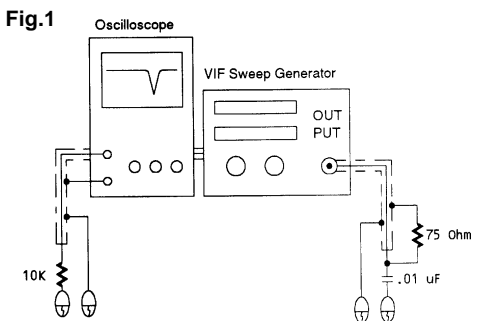
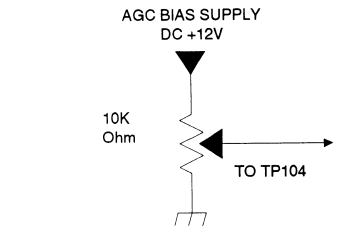

ALIGNMENT	
TO GND	TO SA101 Pin 4
TO GND	TO TUNER TP
	TANK
	VIF

B. ALIGNMENT STEP (SEE FIG.3)

1. Adjust T105 (TANK COIL) to obtain maximum amplitude of response at 39.5MHz as in Fig.3.

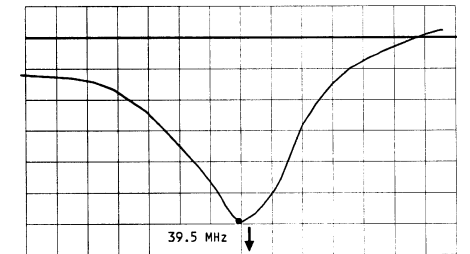

Fig. 3

IV. VIF ALIGNMENT (TUNER VIF COIL)

A. PREPARATION STEP (SEE FIG.4)

1. Connect the output of VIF Sweep Generator between tuner test point TP and tuner case with input level of 54dBpV.
2. Connect resistor (100 Ohm) between TP101 and TP102.
3. Connect the vertical input of the Oscilloscope to the TP106 and ground.
4. Apply a +14V DC to lead of D408.
5. Apply a AGC bias (approx 6.14V) to TP104.

B. ALIGNMENT

1. Adjust AGC bias voltage slowly until the waveform is just before saturation.
2. Adjust the vertical gain control of the Oscilloscope until the waveform is 10 division on the screen.
3. Adjust the ferrete core in the tuner until the marker 39.5MHz has maximum amplitude and 35.07MHz has a difference of 1 division as shown in Fig.4.

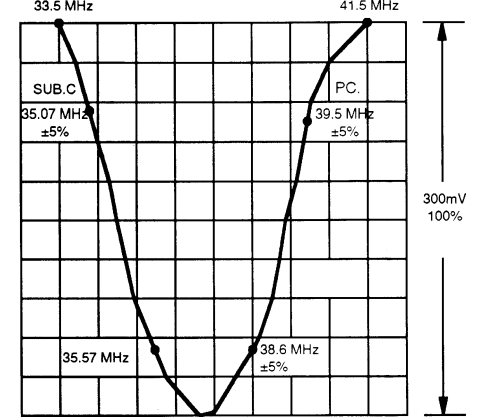

Fig. 4

V. AFC ALIGNMENT

A. PREPARATION STEP (SEE FIG.5)

1. Connect the signal output of Sweep/Marker Generator to TUNER IF OUTPUT with a signal level of 75dBpV.
2. Connect the vertical input terminal of Oscilloscope to TP107.
3. Apply a +14V DC to lead of D408.
4. Apply a +6.14V DC to TP104.

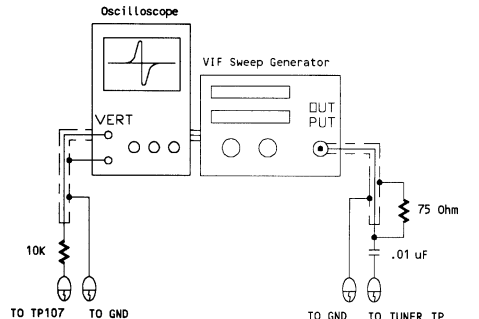

Fig. 5

B. ALIGNMENT STEP

1. Adjust the AGC bias voltage slowly until bottom portion of the waveform is just before saturation.
3. Adjust T106 (AFC COIL) for a waveform as shown in Fig.6.

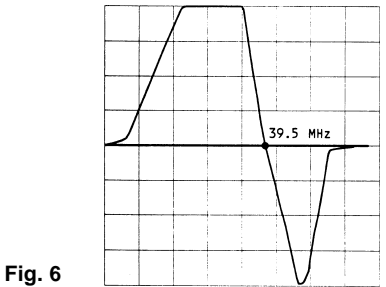

Fig. 6

VI. SIF ALIGNMENT

A. PREPARATION STEP (SEE FIG.7)

1. Connect the output of SIF Sweep Generator between TP106 and ground.
2. Connect the vertical input of Oscilloscope between TP105 and ground.
3. Supply DC +14V to (+) lead of D408.

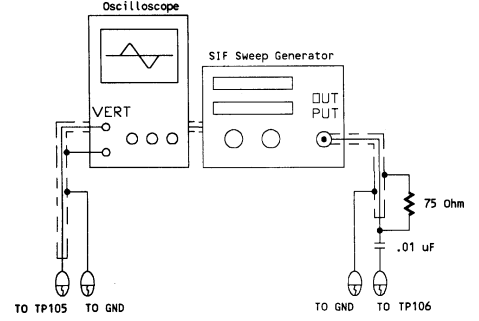

Fig. 7

B. ALIGNMENT STEP

1. Adjust the output of Sweep Generator until a similar waveform is obtained (Fig.8).
 2. Adjust T104 to obtain the marker 6.0MHz rested on the horizontal line (Fig.8).
- NOTE: Input Level = 90dB.

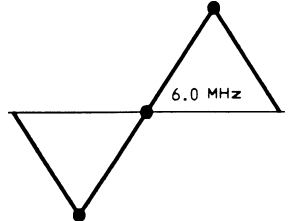

Fig. 8

VII. B+ ADJUSTMENT

1. Connect the digital voltmeter to TP401.
2. Adjust semi-fixed resistor VR901 until meter reading DC 112.25V ± 0.25V.

VIII. HORIZONTAL CIRCUIT ADJUSTMENT

1. Connect the frequency counter to the heater of the CRT and ground.
2. Set the TV set to AV mode without any input signal.
3. Adjust the VR303 until the frequency is 15.625KHz ± 20Hz.
4. Set the TV set to TV mode and Receive Monoscope Pattern.
5. Adjust VR302 to move the pattern horizontally for center position.

IX. VERTICAL CIRCUIT ADJUSTMENT

1. Connect the frequency counter between V-deflection yoke and ground..
2. Set the TV to AV mode without any input signal.
3. Adjust the V-hold VR304 until the counter reads 44Hz ± 1 Hz
4. Set the TV set to TV mode and Receive Monoscope Pattern.
5. Adjust V-SIZE (VR401) control to obtain a normal picture.

X. FOCUS ADJUSTMENT

1. Set Contrast control to maximum position and Brightness control to middle position.
2. Adjust Focus control (on the FBT) to obtain a sharpest picture on the CRT.

XI. COLOUR DEMODULATOR ALIGNMENT, DELAY LINE ALIGNMENT

1. Receive Philips Pattern.
2. Set Contrast control to minimum position.
3. Set Colour control to maximum position.
4. Connect Oscilloscope to TP301 (B-out).
5. Adjust CT301 to obtain the waveform as in Fig.9.
6. Adjust VR301 to obtain the waveform as in Fig.9.
7. Adjust T301 to obtain the waveform as in Fig.9.

XII. RF AGC

1. Connect a TV signal (60dB) from centre system to the tuner.
2. A digital voltmeter is connected to the AGC terminal of tuner (Pin 4).
3. Adjust VR101 until the voltmeter reads 4.8V.

XIII. ON SCREEN ADJUSTMENT (SEE FIG 10)

1. Receive the Monoscope Pattern.
2. Press the volume control.
3. Adjust OSD (VR601) so that the On Screen Display is at center position.

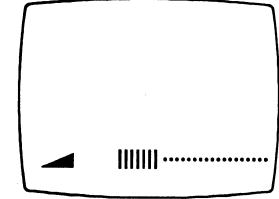

Fig. 10

XIV. WHITE BALANCE ADJUSTMENT

1. Receive a Monoscope Pattern picture signal.
2. Turn the red, green and blue LOW LIGHT (VR501, VR502, VR503) controls to middle position and turn the DRIVE (VR504, VR505) control to middle position.
3. Turn the Screen control on the FBT to minimum position.
4. Set the Sub-Brightness (VR305) control to middle position, then set the Contrast control and Colour control to minimum position.
5. CN403 (Pin 1,2) with Join together.
6. Connect volt meter between (R508) and ground, and adjust Brightness control to the reading of DC 138V (±2V). If DC 138V cannot be obtain, adjust the Sub-Brightness control (VR305).
7. Slowly turn the Screen control clockwise to the point where a horizontal line just illuminates.
8. Adjust VR501 to get a red horizontal line on CRT.
9. Adjust VR502 to get a yellow horizontal line on CRT.
10. Adjust VR503 to get a white horizontal line on CRT.
11. Reset the Service Switch (S401) to "NORMAL" position and turn Brightness control to middle position.
12. Adjust Drive (VR504, VR505) control to obtain a uniform white picture.

XV. SUB-BRIGHTNESS ALIGNMENT

1. Receive a Monoscope Pattern.
2. Set controls as follows
BRIGHTNESS control.....CENTER position.
CONTRAST control.....CENTER position.
COLOUR control.....CENTER position.
3. Adjust SUB-BRIGHTNESS (VR305) to get NINE step of the grey scale just illuminate in monoscope pattern as shown in Fig 11.

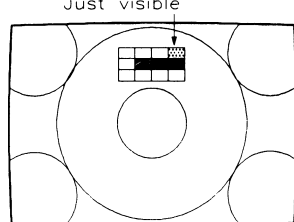

Fig. 11

XVI. COLOUR PURITY ADJUSTMENT (SEE FIG.12)

- BEFORE ALL ADJUSTMENT DESCRIBED BELOW ARE ATTEMPTED, V-HOLD, H-HOLD, V-HIGH, B+ VOLTAGE AND FOCUSING ADJUSTMENT MUST BE COMPLETED.

1. Place the TV receiver facing NORTH or SOUTH.
2. Plug in TV receiver and turn in on.
3. Operate the TV receiver over 30 minutes.

4. Fully degauss the TV receiver by using an external degaussing coil.
5. Receive a crosshatch pattern and adjust the static convergence, control roughly.
6. Loosen the clamp screw of the deflection yoke and pull the deflection yoke towards you.
7. Fully turn the red and blue Drive (VR503, VR505) controls counter-clockwise.
8. Adjust the purity magnets so that green field is obtained at the center of the screen.
9. Slowly push the deflection yoke towards bell of CRT and set it where a uniform green field is obtained.
10. Tighten the clamp screw of the deflection yoke.

XVII. CONVERGENCE ADJUSTMENT (SEE FIG.12)

1. Receive a crosshatch pattern.
2. Unfix the convergence magnet damper and align red with blue dots at the center of the screen by rotating (RB) static convergence magnets.
3. Align Red/Blue with green dots at the center of the screen by rotating (RB-G) static convergence magnet.

4. Fix the convergence magnets by turning the damper.
5. Remove the DY wedges and slightly tilt the deflection yoke horizontally and vertically to obtain the good overall convergence.
6. Fix the deflection yoke by wedges.
7. If purity error is found, follow "PURITY ADJUSTMENT" instructions.

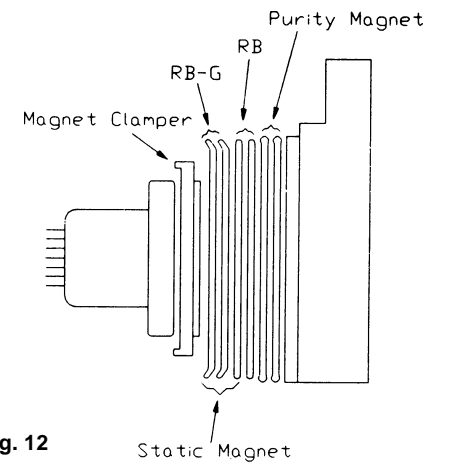
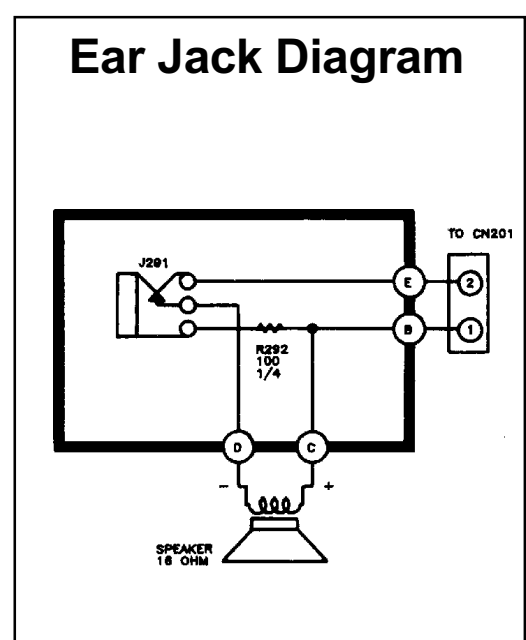
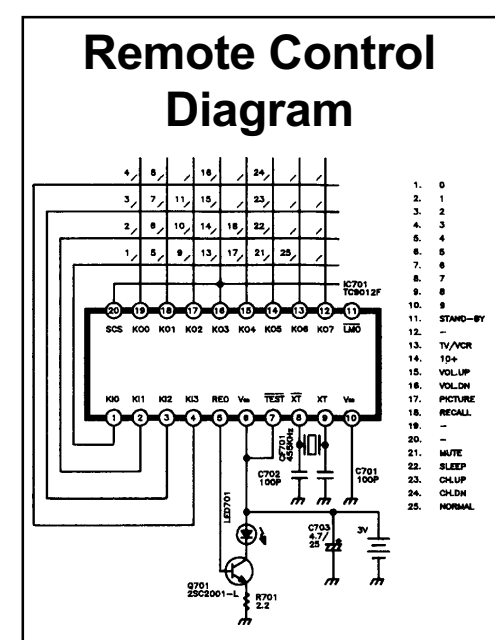
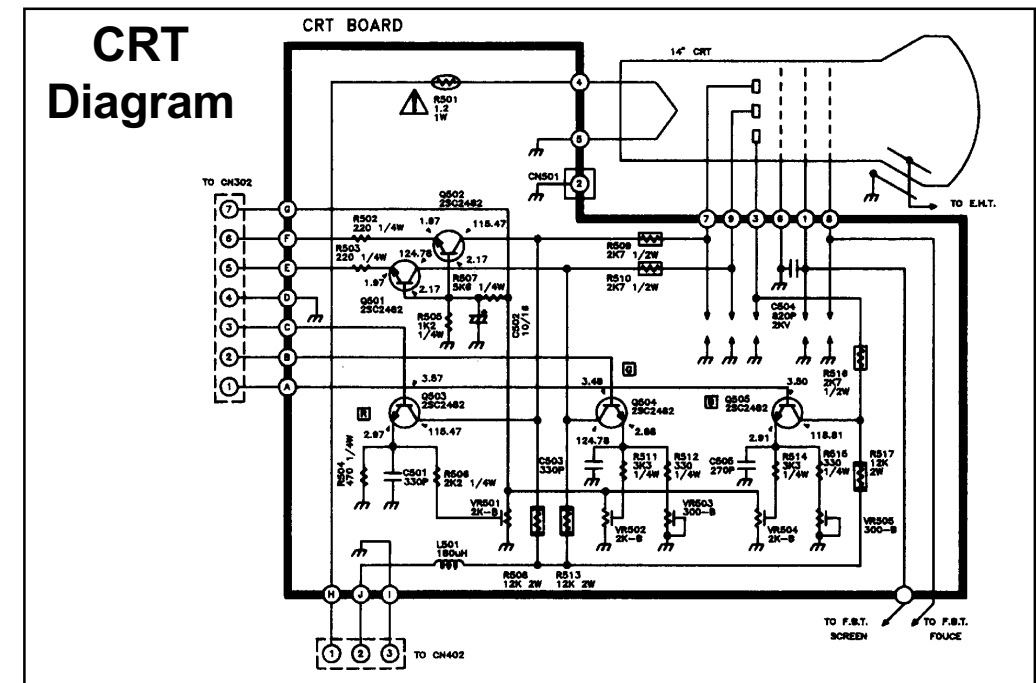

Fig. 12



Main Diagram

